

# SoundPlus®

Infrared Listening System

**QUICK SETUP GUIDE**

Transmitter Model WIR TX90



## Quick Setup Instructions

---

### Step 1: Determine Location/Coverage

Prior to connecting the power supply and audio source, consider where TX90 will be installed for best coverage of the listening area. Ideally, the TX90 should be pointed toward the listening audience where the receivers can pick-up the TX90's transmission line-of-sight. See manual for coverage drawings.

### Step 2: Connect Power

Connect the supplied power supply to the back of the TX90 (figure 1). The red LED "Power On" indicator will illuminate.

### Step 3: Connect Audio Source

For single channel mode, plug the audio cable with the installed Phoenix connector in "Channel A" OR the "Channel B" connector. For two channel operation, plug the audio cables with Phoenix connectors in both "Channel A" AND "Channel B" connector. NOTE: By default, the WIR TX90 is set to operate in two channel mode. To turn Channel A or Channel B on/off, refer to the instructions in Step 5. For optimal performance, turn OFF channels not in use.

### Step 4: Selecting a Frequency

The TX90 offers two sets of carrier frequencies for Channel A and Channel B: 2.3 and 2.8MHz or 3.3 and 3.8MHz. The TX90 is preset to 2.3 and 2.8MHz. Move the slide switch to select a pair of operating frequencies.

### Step 5: Selecting a Channel

To activate a channel, press the "CHANNEL" button until the channel "ON" indicator lights. To operate both channel A and B, press the "CHANNEL" button until both "ON" indicators light.

### Step 6: Select the Audio Processing Application Preset

The TX90 offers three presets for the most common audio applications: Music, Voice, and Hearing Assist. The TX90 is factory set "Music" mode for maximum audio quality. To change this preset, press "CHANNEL" button to active channel to set preset for, then press the "PRESETS" button until indicator light shows your selection. After 10 seconds, the setting will be stored.

### Step 7: Adjust Audio Input Level

To adjust the audio input level, first activate the channel(s) you want to adjust by pressing the "CHANNEL" button, then press the "VOLUME" button. Turn the "ADJUST" knob clockwise to increase the input signal or counter-clockwise to decrease the input signal until the channel "Level" indicator is flashing. After 10 seconds, the setting will be stored.

Audio level NORMAL (optimal): the audio indicator level will **flash at a 1 second rate**.

Audio level too HIGH: the audio indicator level will **stay on** or **flash erratically**.

Audio level too LOW: the audio indicator level will be **off**.

### Step 8: Adjust Tone

To adjust the tone, first activate the channel(s) you want to adjust by pressing the "CHANNEL" button, then press the "TONE" button. The tone indicator will light. Now turn the "ADJUST" knob clockwise to emphasize high frequencies (best for hearing assistance use) and counter-clockwise to decrease the high frequency emphasis. After 10 seconds, the setting will be stored.

### Step 9: Listen with Receiver

Important: Make sure the infrared receiver being used is on the same frequency as the WIR TX90! Refer to the operating instructions that came with your receiver.

**See manual for detailed descriptions and instructions. If you are still having difficulty with your system, please call customer service at 800-843-3544.**

Figure 1: WIR TX90 Connections Diagram

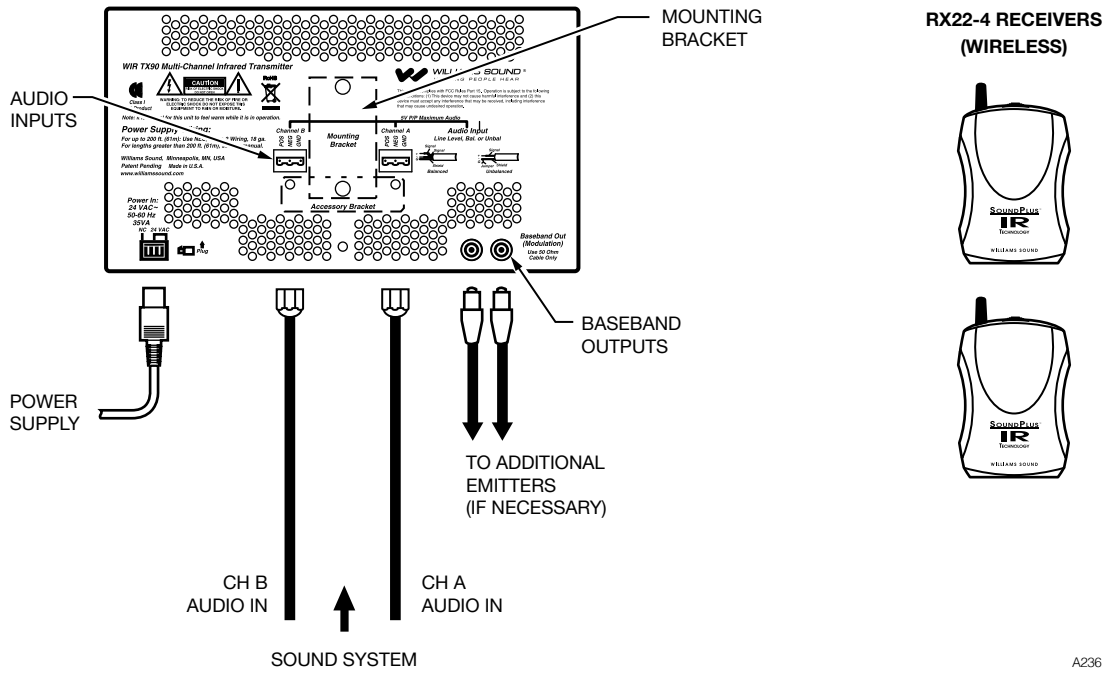

A236

Figure 2: WIR TX90 Features & Controls

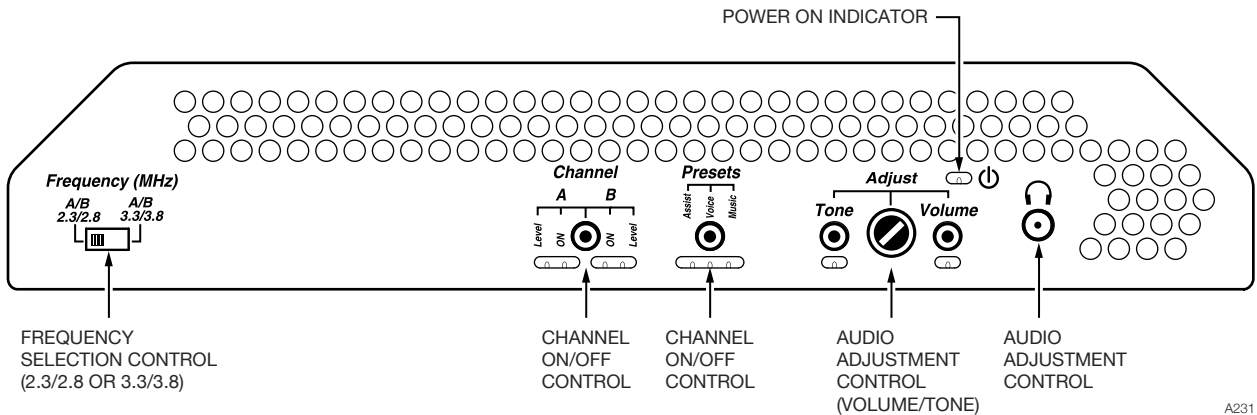

A231

