



WILLIAMS SOUND®
Helping People Hear

MANUAL AND USER GUIDE

INTERPRETER CONTROL CENTER

Audio Control Center For Simultaneous Interpreters

Model IC-1

INTERPRETER CONTROL CENTER, MODEL IC-1

INSTALLATION GUIDE & USER MANUAL

<u>Contents</u>	<u>Page</u>
Overview	4
Safety Information	5
Recycling Instructions	5
Initial Setup	6
Audio Connections	8
Audio Inputs	
Audio Outputs	
Switches & Controls	9
AC Power	10
Switches & Controls	9
Configuration Examples	11
Sequential Interpretation	
Simultaneous Interpretation	
Limited Warranty	14
Specifications	16

OVERVIEW

The IC-1 is a self-contained audio control center designed to provide all the functions necessary for simultaneous interpretation of one or more languages. As a stand-alone unit, it allows one or two interpreters to monitor floor or relay sources, activate one or both microphone inputs, and route the interpretation signal to one of two language groups. Additional IC-1's can be cascaded for simultaneous language interpretation applications. Each interpreter has the option of using a headset/microphone combination or separate microphones and headphones.

The IC-1 is suitable for “presentation-style” conferences for 1-4 language groups, in which there is only one presenter at a time at the podium. The IC-1 is not suitable for “delegate-style” conferences where a number of delegates speaking a number of different languages are carrying on a dialog or debate.

If you need assistance with this product, contact Williams Sound Customer Service at 1-800-843-3544 or 952-943-2252 for further assistance.

SAFETY INFORMATION

HEARING SAFETY



CAUTION!

This product is designed to amplify sounds to a high volume level which could potentially cause hearing damage if used improperly. **To protect your hearing and the hearing of others:**

1. Make sure the volume is turned down before putting on the earphone or headphone before adjusting the volume to a comfortable level.
2. Set the volume level at the minimum setting that you need to hear.
3. If you experience feedback (a squealing or howling sound), reduce the volume setting and move the microphone away from the earphone or headphone.
4. Do not allow children **or other unauthorized persons** to have access to this product.

PACEMAKER SAFETY:



CAUTION!

1. **Before** using this product with a pacemaker or other medical device, consult your physician or the manufacturer of your pacemaker or other medical device.
2. If you have a pacemaker or other medical device, make sure that you are using this product in accordance with safety guidelines established by your physician or the pacemaker manufacturer.

RECYCLING INSTRUCTIONS



Help Williams Sound protect the environment! Please take the time to dispose of your equipment properly.

Product Recycling for Customers in the European Union:

Please do NOT dispose of your Williams Sound equipment in the household trash. Please take the equipment to a electronics recycling center; OR return the product to the factory for proper disposal.



11/10/06

INITIAL SET-UP

- Step 1: Plug the cord from the power supply into the DC power connector on the rear panel of the IC-1. Plug the AC cord into an AC power outlet.
- Spike protection and RF filtering on the AC power line are recommended. In some cases, a ground isolation plug may be needed to eliminate ground loops with other equipment.
- Step 2: Plug a microphone into the mic input jack on the IC-1. Condenser microphones are preferred for higher output and lower noise levels. Use the mic switch to select the input you are using (left or right). Headset-type microphones work best.
- Step 3: Turn the headphone volume controls all the way down and plug stereo or mono headphones into the headphone jack.
- Step 4: Plug a line-level audio signal from the floor language source into the floor input (FLOOR IN) on the IC-1 rear panel.
- Step 5: Press the OFF button on the mode selector. Slowly turn the headphone volume up. You should be able to hear the floor signal in the headphones.
- Step 6: Connect the IC-1 NORM OUT jack to the audio input of an FM Transmitter or Infrared Modulator.
- Step 7: Press the NORM button on the IC-1. Speaking into the microphone should cause the audio indicator to flash on the transmitter or modulator and you should be able to hear the microphone signal with a receiver. Adjust the transmitter input level control, if necessary.
- Step 8: While talking, hold the MUTE button down. The mic signal should mute in the receiver. Release the button and the mic signal should return.
- Note: If you experience crosstalk between the floor or relay inputs and the norm or key outputs, reduce the signal level into the IC-1 inputs at the source.

FIGURE 1: IC-1 SIGNAL FLOWS

**OFF
SELECTED**

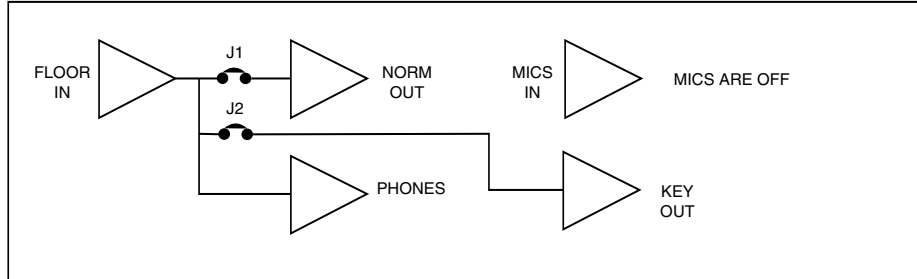

**NORM
SELECTED**

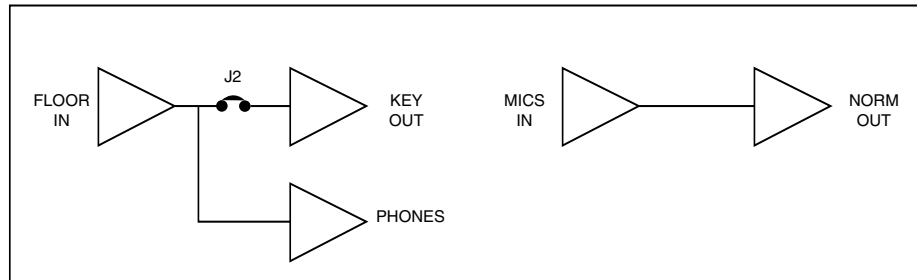

**RELAY
SELECTED**

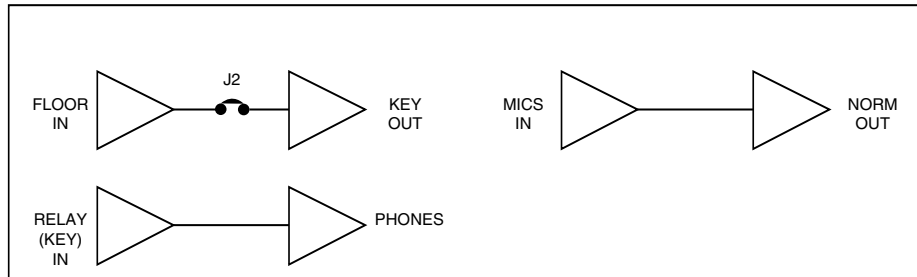

**KEY
SELECTED**

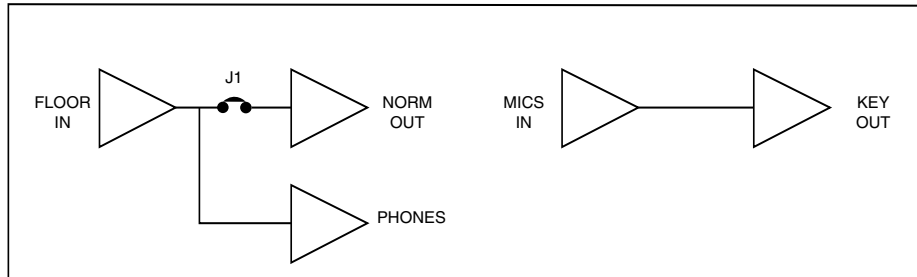

AUDIO CONNECTIONS

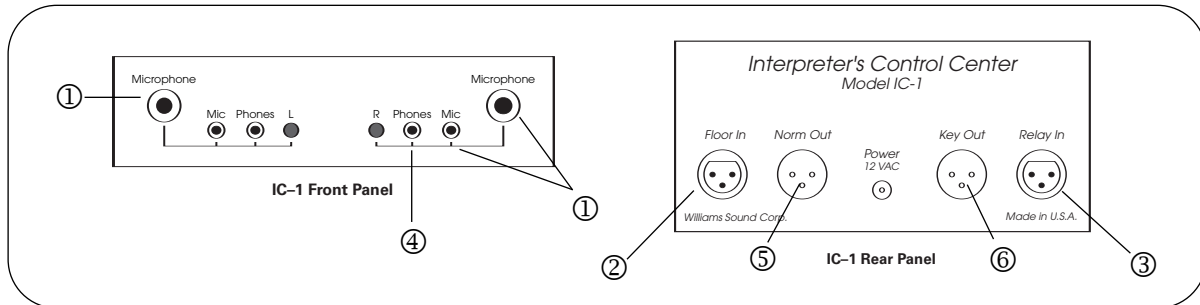

AUDIO INPUTS

① MICROPHONE INPUTS

Two microphone inputs are provided for each interpreter to accommodate a wide variety of microphones. The technician may choose to use either the balanced 1/4" phone jack or the unbalanced 1/8" mini jack inputs. DC power is supplied for electret microphones on both inputs. Only one mic input per interpreter should be used. Condenser microphones are strongly recommended.

② FLOOR INPUT

A female XLR jack on the rear panel allows a balanced or unbalanced line-level floor language signal to be connected directly to the IC-1. The floor signal is selected for monitoring whenever the OFF, NORM, or KEY modes are selected. This signal will most likely come from the mixer connected to the microphones used to pick up the presenter's voice (podium mic).

③ RELAY INPUT

A female XLR jack on the rear panel will allow a second balanced or unbalanced line-level signal to be connected directly to the IC-1. This input is selected for monitoring whenever the RELAY mode is selected. This signal will most likely come from the normal output (NORM OUT) of the IC-1 in the translation booth working into a common "key" language. For example, English is frequently the "key" language common to all interpreters when working in the United States.

AUDIO OUTPUTS

④ HEADPHONE JACKS

Two stereo 1/8" mini phone jacks are provided on the IC-1 front panel. The headphone output will accommodate mono or stereo, low-impedance (8-32 Ω) earphones or headphones.

⑤ NORMAL OUTPUT

A male XLR jack is provided on the rear panel to allow balanced or unbalanced direct connection to an FM transmitter, infrared transmitter, or tape recorder. When connection to more than one device is needed, a distribution amplifier may be used. The interpreter's microphones are routed to the normal output (NORM OUT) whenever the NORM or RELAY modes are selected.

⑥ KEY OUTPUT

A male XLR jack is provided on the rear panel to allow balanced or unbalanced auxiliary output. The interpreter's microphones are routed to the key output (KEY OUT) whenever the KEY mode is selected. A typical use for the relay output is to allow a team of two interpreters to feed a second language transmitter. The interpreters change languages by alternating between NORM and KEY modes.

SWITCHES AND CONTROLS

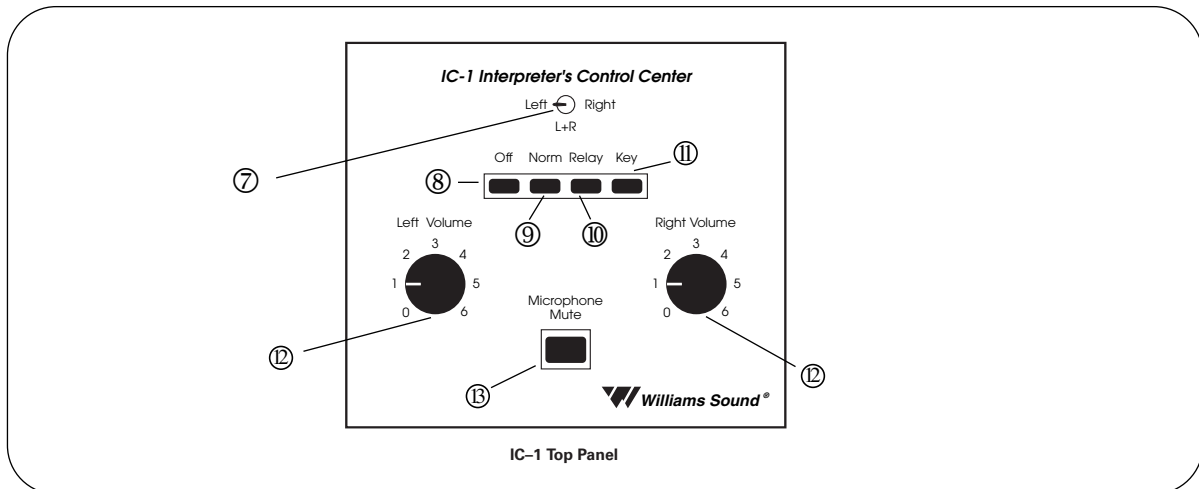

⑦ MICROPHONE SWITCH

A 3-way toggle switch on the top panel selects the active microphone. The interpreter can select left mic, right mic, or left and right mics. LED lights indicate the active microphone. The LEDs also serve as power on indicators.

MODE SELECTOR SWITCH

Four push buttons on the top panel select the operating mode. See Figure 1 for signal flows.

⑧ OFF

The floor input (FLOOR IN) is fed to the interpreter's headsets to allow monitoring of the meeting. Interpreter's microphones are muted.

⑨ NORM

The floor input (FLOOR IN) is fed to the interpreter's headsets for interpretation. The selected interpreter's microphone is fed to the normal output (NORM OUT).

⑩ RELAY

The interpreters are now monitoring the relay input (RELAY or KEY IN) while the selected microphone feeds the normal output (NORM OUT).

⑪ KEY

This mode is used to feed a second language audience. The interpreters are monitoring the floor input (FLOOR IN) but their microphones are now feeding the key output (KEY OUT).

⑫ HEADPHONE VOLUME CONTROLS

Separate volume controls are provided for each headphone output jack. If it is necessary to set the volume above 5, this indicates the floor or key input signal is too weak. Have a technician increase the signal level at the source.

⑬ MICROPHONE MUTE

Pressing and holding the MIC MUTE switch will interrupt both interpreter's microphones. It is typically used as a cough switch. Releasing the button restores the microphone signal.

AC POWER

The standard TFP 008 Power Supply operates on 110VAC, 60Hz and provides 12VAC through a DC plug. A 240VAC power supply is available as well.

FEEDTHROUGH JUMPERS

The feedthrough jumpers are accessible through a hole in the bottom of the IC-1 cabinet. These jumpers allow the floor input (FLOOR IN) signal to be routed to whichever IC-1 output (NORM OUT or KEY OUT) is not receiving the signal from the interpreter's microphone. The feedthrough is activated by placing the provided jumper across the gold pins on the circuit board. The standard configuration is J1 closed and J2 open. On E-series IC-1's, both J1 and J2 can be closed.

Jumper 1 (J1): feeds the floor signal to the normal output (NORM OUT)

Jumper 2 (J2): feeds the floor signal to the key output (RELAY OUT)

APPLICATIONS

The IC-1 Interpreter Control Center is designed for applications that do not require the expense and complexity of a full conferencing system. The main limitation of an interpretation system based on the IC-1 is that interpreters do not have the capability of monitoring all of the other interpreters. When using the IC-1, an interpreter can choose to monitor either the floor (podium) language or one other interpreter who has been designated as the "Key" language interpreter.

THE IC-1 IS SUITABLE FOR THE FOLLOWING APPLICATIONS:

"Presentation style" conferences for one to four language groups. In these applications, there is only one presenter at a time at the podium.

Each language group requires an IC-1 and an interpreter. Each interpreter can monitor either the floor language or the "Key" language interpreter. The "Key" language position is hard-wired. Changing to a different interpreter in the "Key" position requires the interpreters to physically exchange places or rewire the system set-up.

THE IC-1 IS NOT SUITABLE FOR THE FOLLOWING APPLICATIONS:

"Delegate style" conferences where a number of delegates speaking different languages are carrying on a dialog or debate. The floor (podium) shifts rapidly from delegate to delegate. A complete conference system is needed for this type of application.

CONFIGURATION EXAMPLES

SEQUENTIAL INTERPRETATION

TWO LANGUAGES: ONE IC-1, ONE INTERPRETER

The interpreter monitors the floor signal via the FLOOR IN connection and chooses the NORM button to send her microphone signal to Transmitter 1 (TX1) via the NORM OUT connection. Choosing the KEY button sends her microphone signal to Transmitter 2 (TX2) via the KEY OUT connection. Since there is only one interpreter, the microphone switch does not have to be moved. (See Figure 2.)

TWO LANGUAGES: ONE IC-1, TWO INTERPRETERS

Both interpreters monitor the floor signal via the FLOOR IN connection. Interpreter 1 turns her mic ON and chooses NORM to send her voice to Transmitter 1 (TX1) via the NORM OUT connection. When the first interpreter is finished, Interpreter 2 moves the mic switch to turn her microphone ON and chooses the KEY button to send her microphone signal to Transmitter 2 (TX2) via the KEY OUT connection. (See Figure 2.)

For *simultaneous* interpretation of two languages, two IC-1's are needed. See the Figure 4.

FIGURE 2: SEQUENTIAL INTERPRETATION

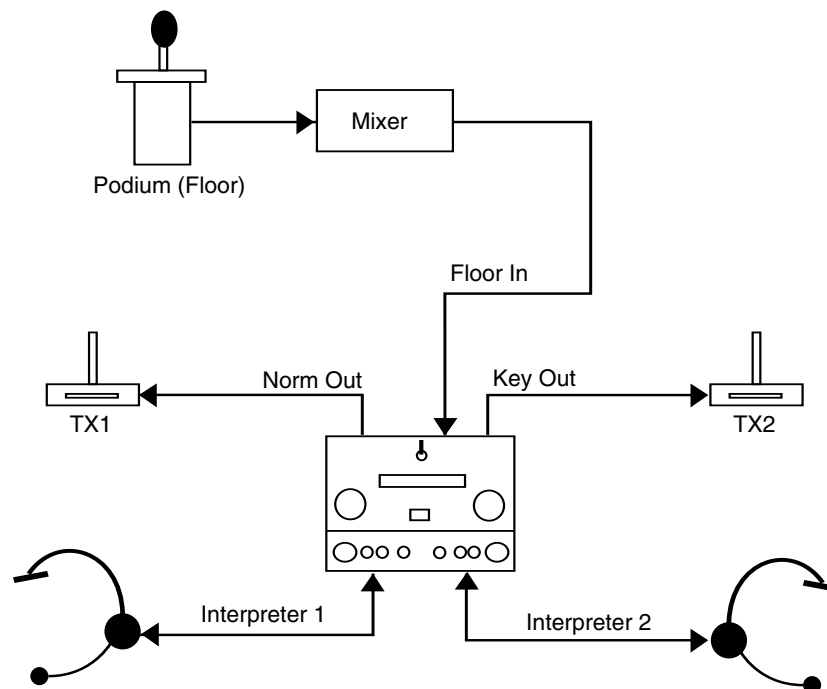

SIMULTANEOUS INTERPRETATION EXAMPLES

TWO LANGUAGES: ONE IC-1, ONE OR TWO INTERPRETERS

In Figure 3a, the floor is English, NORM is selected on IC-1. In Figure 3b, the floor language has changed to Spanish. Key is selected on the IC-1.

FIGURE 3A: SIMULTANEOUS INTERPRETATION (FLOOR LANGUAGE: ENGLISH)

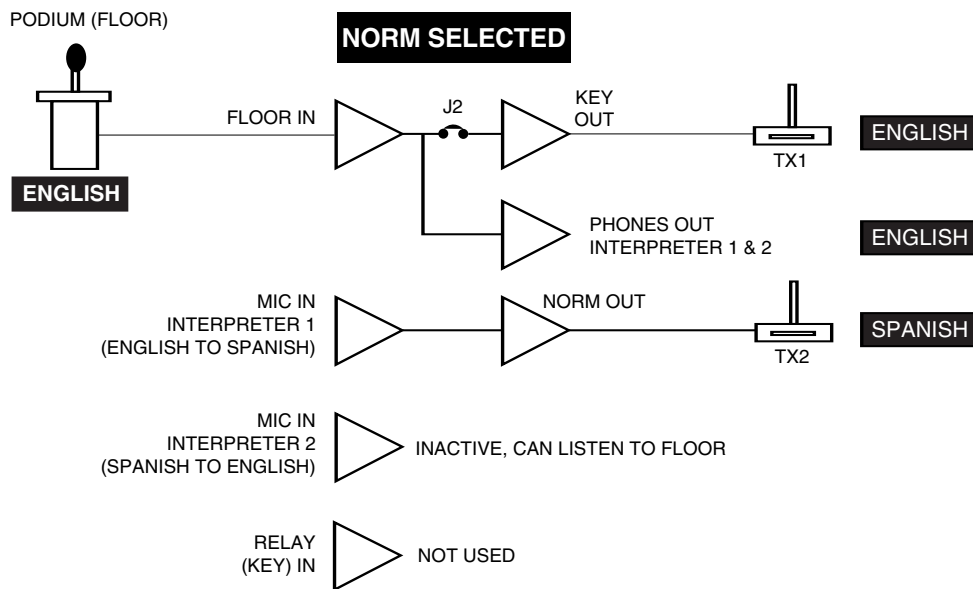
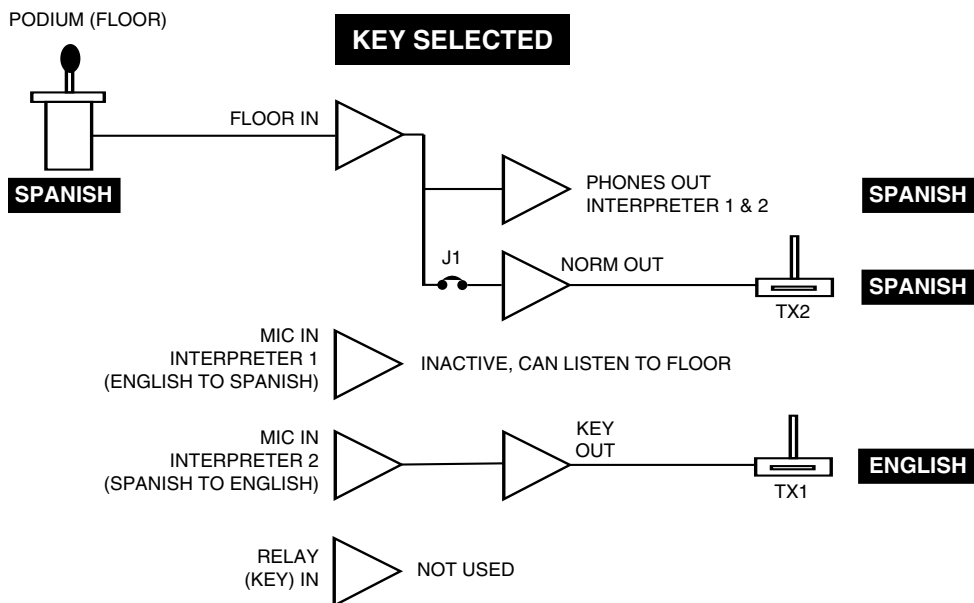

FIGURE 3B: SIMULTANEOUS INTERPRETATION (FLOOR LANGUAGE: NON-ENGLISH)



TWO LANGUAGES: TWO IC-1s, TWO INTERPRETERS

Each Interpreter operates independently. Both monitor the floor signal via the FLOOR IN connection. A distribution amplifier is needed to provide the floor signal to both IC-1's.

Interpreter 1 selects the NORM button to send her microphone signal to Transmitter 1 via the NORM OUT connection.

Interpreter 2 selects the NORM button to send her voice to Transmitter 2 via the NORM OUT connection.

With J1 closed on both IC-1's, the floor signal will feed thru the NORM OUT connection to the Transmitter when the interpreter selects OFF. This allows the listeners to hear the floor language directly when it is their native language.

FIGURE 4: SIMULTANEOUS INTERPRETATION (TWO LANG., TWO INTERP.)

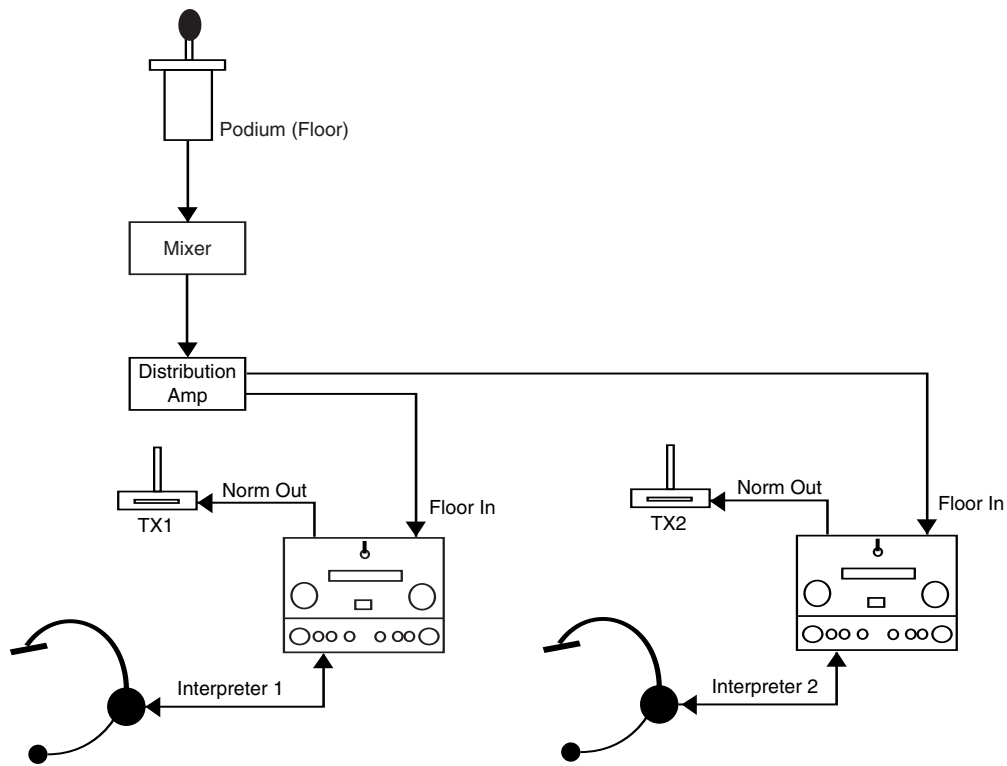

THREE LANGUAGES, TWO IC-1s, TWO INTERPRETERS

This set-up can be used in two ways: (Situation 1) it allows two interpreters to work three languages when the floor language doesn't change and both interpreters understand the floor language, or (Situation 2) when the floor language does change and one of the interpreters does not understand the floor language, but does understand the other interpreter.

SITUATION 1

Each interpreter operates independently. Both monitor the floor signal via the FLOOR IN connection. A distribution amplifier is needed to provide the floor signal to each IC-1. The NORM OUT jack of each IC-1 is connected to a transmitter (TX2 and TX3) to provide language 2 and language 3.

The KEY OUT connection from each IC-1 is connected to a mixer to allow either interpreter to provide a relay signal. A distribution amplifier sends the relay signal to the RELAY IN connection of each IC-2 and to a third transmitter (TX1).

Each interpreter selects the NORM button to send her microphone signal via the NORM OUT connection to the transmitter for their language. When both interpreters are using the NORM mode, the floor signal feeds through J2 (if it is closed) to the KEY OUT jacks of both IC-1s. The signal then feeds to the TX1 through the distribution amplifier. This would allow listeners to hear the floor signal (language 1) on channel 2 and language 3 on channel 3.

SITUATION 2

One of the interpreters acts as the "key language" source. The interpreters can take turns providing the key language if they wish. If Interpreter 1 is going to provide the relay signal, he or she selects the KEY mode while interpreter 2 selects the RELAY mode. Now Interpreter 1 will hear the floor signal (language 1) and their microphone will be connected to the KEY OUT jack, which feeds the RELAY IN jack of the second interpreter's console and also Transmitter TX3 through the mixer and distribution amplifiers.

If J1 is closed on Interpreter 1's console, the floor signal will feed-thru the NORM OUT connection to the Transmitter TX2.

With Interpreter 2 in the RELAY mode, they will be listening to Interpreter 1 via the RELAY IN connection. their microphone will be connected to the NORM OUT jack to Transmitter TX3. J2 should be open on the Interpreter 2's console. J1 may be closed.

If Interpreter 2 is going to provide the Relay signal, he or she selects the KEY mode on their console and interpreter 1 selects the RELAY mode on their console.

If you need help with alternate set-ups, contact Williams Sound Customer Service at 1-800-843-3544 or 952-943-2252 for further assistance.

FIGURE 5: SIMULTANEOUS INTERPRETATION (THREE LANGUAGES, TWO IC-1s, TWO INTERPRETERS)

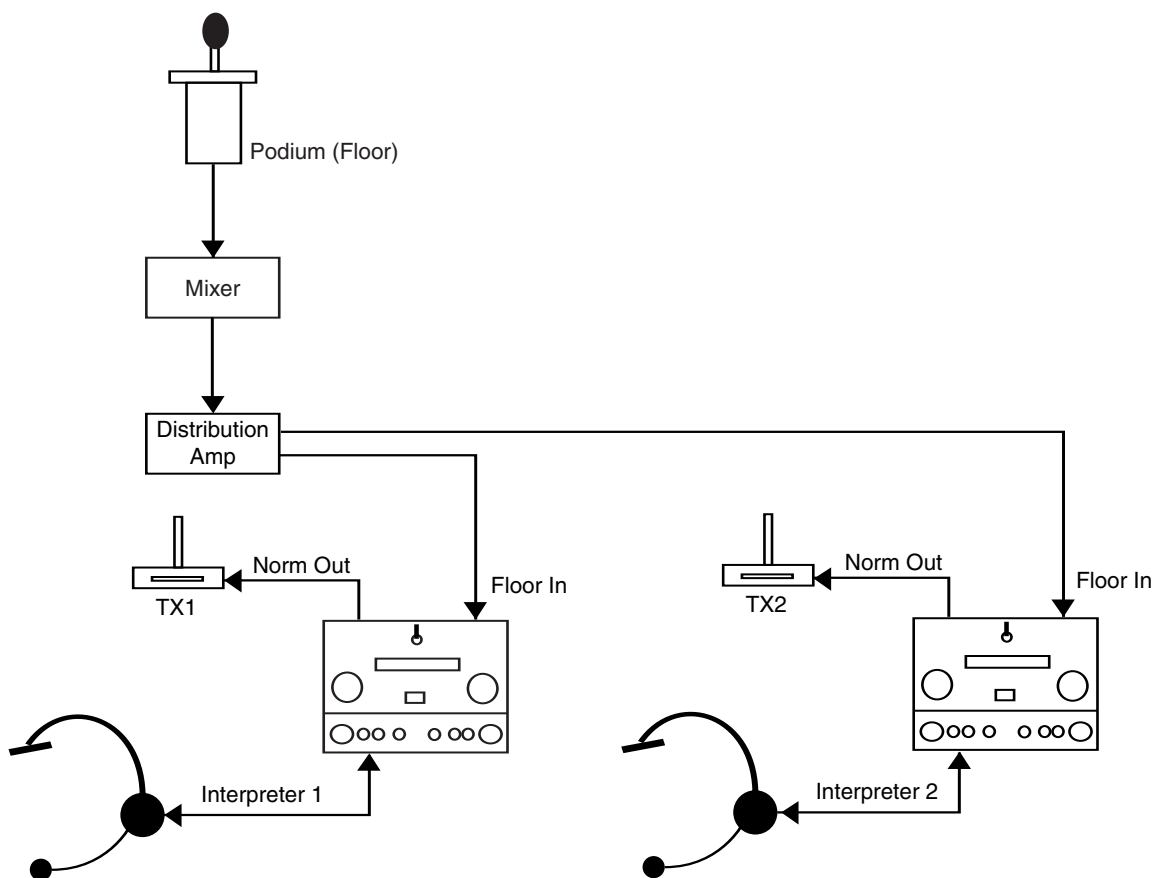

FOUR LANGUAGES: 4 IC-1s, 4 INTERPRETERS W/RELAY FUNCTION

Each Interpreter operates independently. All monitor the floor signal via the FLOOR IN connection. A distribution amplifier is needed to provide the floor signal to each IC-1. Each interpreter selects the NORM button to send her microphone signal via the NORM OUT connection to the Transmitter for their language .

The “Pivot” person (usually the English interpreter) provides the relay signal via the NORM OUT connection to a second distribution amplifier. The distribution amplifier sends the relay signal to the English transmitter and to each of the other interpreters via the RELAY IN connection on their IC-1.

When the other three interpreters select NORM, they are listening to the original floor signal and their voice is being sent to their transmitter. When they select RELAY, they are listening to the pivot interpreter (usually speaking English) and their voice is sent to their transmitter.

With J1 closed on all IC-1’s, the floor signal will feedthru the NORM OUT connection to the Transmitter when the interpreter selects OFF. This allows the listeners to hear the floor language directly when it is their native language.

FIGURE 6: SIMULTANEOUS INTERPRETATION (MULTIPLE LANGUAGES)

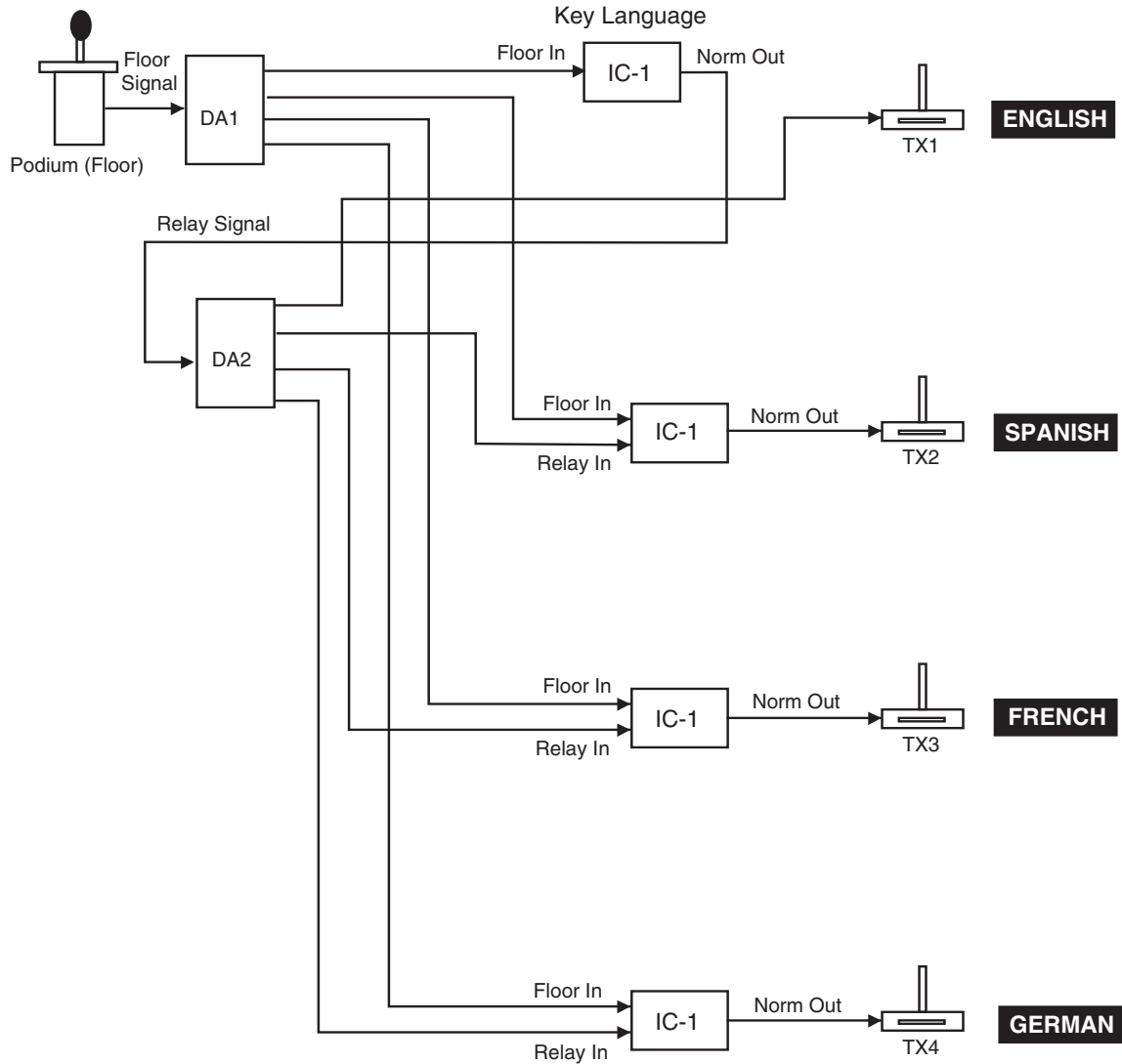

LIMITED WARRANTY

Williams Sound products are engineered, designed, and manufactured under carefully controlled conditions to provide you with many years of reliable service. Williams Sound warrants the Interpreter Control Center against defects in materials and workmanship for FIVE (5) years. During the first five years from the purchase date, we will promptly repair or replace the Interpreter Control Center.

Microphones, earphones, headphones, batteries, chargers, cables, carry cases, and all other accessory products carry a 90-day warranty.

WILLIAMS SOUND HAS NO CONTROL OVER THE CONDITIONS UNDER WHICH THIS PRODUCT IS USED. WILLIAMS SOUND, THEREFORE, DISCLAIMS ALL WARRANTIES NOT SET FORTH ABOVE, BOTH EXPRESS AND IMPLIED, WITH RESPECT TO THE INTERPRETER CONTROL CENTER, INCLUDING BUT NOT LIMITED TO, ANY IMPLIED WARRANTY OF MERCHANTABILITY OR FITNESS FOR A PARTICULAR PURPOSE. WILLIAMS SOUND SHALL NOT BE LIABLE TO ANY PERSON OR ENTITY FOR ANY MEDICAL EXPENSES OR ANY DIRECT, INCIDENTAL OR CONSEQUENTIAL DAMAGES CAUSED BY ANY USE, DEFECT, FAILURE OR MALFUNCTIONING OF THE PRODUCT, WHETHER A CLAIM FOR SUCH DAMAGES IS BASED UPON WARRANTY, CONTRACT, TORT OR OTHERWISE, THE SOLE REMEDY FOR ANY DEFECT, FAILURE OR MALFUNCTION OF THE PRODUCTS REPLACEMENT OF THE PRODUCT. NO PERSON HAS ANY AUTHORITY TO BIND WILLIAMS SOUND TO ANY REPRESENTATION OR WARRANTY WITH RESPECT TO THE INTERPRETER CONTROL CENTER. UNAUTHORIZED REPAIRS OR MODIFICATIONS WILL VOID THE WARRANTY.

The exclusions and limitations set out above are not intended to, and should not be construed so as to contravene mandatory provisions of applicable law. If any part or term of this Disclaimer of Warranty is held to be illegal, unenforceable, or in conflict with applicable law by a court of competent jurisdiction, the validity of the remaining portions of this Disclaimer of Warranty shall not be affected, and all rights and obligations shall be construed and enforced as if this Limited Warranty did not contain the particular part or term held to be invalid.

If you experience difficulty with your system, call Toll-Free for Customer Assistance:

1-800-843-3544

If it is necessary to return the system for service, your Customer Service Representative will give you a Return Authorization Number (RA) and shipping instruction.

Pack the system carefully and send it to:

**Williams Sound Corp.
Attn: Repair Dept.
10321 West 70th Street
Eden Prairie, MN 55344 USA**

Your warranty becomes effective the date you purchase your system. Your returned warranty card is our way of knowing when your warranty begins. It also gives us important information about your system including the serial number. This information will help us serve you better in the future. Please take a moment to complete and mail the attached card. Thank you.

SYSTEM SPECIFICATIONS

INTERPRETER CONTROL CENTER, MODEL IC-1

Dimensions, Weight: 7" (17.7 cm) W x 5.625" (14.3 cm) D x 3.125" (9.3 cm) H, 1.82 lbs. (.83 kg)
Color: Beige epoxy paint with black legends
Power: External power supply, 12 VAC, 50 or 60 Hz, 10 VA, (TFP 008 Power Supply)
(A 240 VAC Power Supply is also available)

INPUTS

Floor In, Key In: 3-Pin XLR female jack, balanced or unbalanced line-level, Max 3.8 Vrms, Gain 6 dB, 43 k Ω input impedance
1/4" Microphone Inputs: Left and right, 1/4" TRS phone jack, balanced or unbalanced mic-level, Max 70 mVrms, Gain 46 dB, Supplies simplex DC power for electret mics, 1.75 k Ω input impedance
3.5 mm Microphone Inputs: Left and right, 3.5 mm TRS phone jack, unbalanced (T,S) for condenser mics, Max 70 mVrms, Gain 46 dB, Supplies DC power on tip, 1.75 k Ω input impedance

OUTPUTS

Key Out, Norm Out: 3-Pin XLR male jack, balanced or unbalanced line-level, 7.7 Max Vrms, 56 Ω source impedance
Headphones: 3.5 mm TRS phone jack, mono or stereo headphone, 8-32 Ω , 63.7 mW at 8 Ω load max

CONTROLS

Volume: Left and right, rotary, controls headset volume
Mic Switch: 3-way toggle. Selects left mic, right mic, or both
Mute Switch: Push button. Mutes left and right mics when depressed
Function Switch: 4-way push button. Selects OFF, NORM, RELAY, or KEY modes

CONTROLS

Feedthru Jumpers: Located on bottom of cabinet. Used to select floor signal feedthru options.

Approvals: WEEE
Warranty: 5 years, parts and labor (90 days on accessories)

NOTE: SPECIFICATIONS SUBJECT TO CHANGE WITHOUT NOTICE



WILLIAMS SOUND[®]
Helping People Hear

10321 West 70th St., Eden Prairie, MN 55344 U.S.A.
800.843.3544 | 952.943.2252 | FAX: 952.943.2174

© 2006, Williams Sound Corp.

MAN 067E